

Colts Battery 2012



Technique Packet



www.colts.org



Colts Percussion 2012

To All Prospective Members,

Thank you for your interest in the 2012 Colts Percussion Program! The corps has generated a great deal of excitement over the last several years and we are looking forward to continuing that excitement into the 2012 season! It takes a highly motivated individual, fueled by maturity, integrity, and discipline, to perform as a member of The Colts Drum and Bugle Corps. This said, we welcome your audition!

The primary goals of the first two camps are first to orient you, the prospective member, to the standards, techniques, and approaches we employ and secondly to evaluate the talent. Each of you will be assessed in a group setting as well as individually. The staff will maintain a high level of communication with you throughout the weekend(s) giving you constructive feedback.

Members should be familiar with the exercise packet that best fits your interest. Snare, Tenor, Bass Drum, Cymbals, or Front Ensemble. We will provide all instruments for camps. We ask that you provide your own sticks and/or mallets as well as a practice pad. Your preparation will aid not only in your audition, but the overall efficiency of the weekend!

Again, thank you for you interest in the ColtsPercussion Program! If you have any questions please feel free to email me at d1nelson@hotmail.com.

See you at camp!

David Nelson

Colts Drum and Bugle Corp

Cymbal Line 2012

Audition Packet



Sound Production

The single most important aspect of cymbal playing is sound production. The visual effect the cymbal creates, while extremely important, is secondary. At the point of attack using a standard crash, the cymbals should NOT meet exactly together “edge to edge.” This will result in what is called an “air-pocket” which is a momentary vacuum that locks the cymbals together and kills most of the sound. To create a full crash sound, apply a ‘flam’ concept. At the instant of attack, the bottom edges of the cymbals meet first, followed by the top edges. Unlike an actual flam, there should be no audible “grace note.” Using this sound quality technique, the cymbals should resonate to their fullest quality.

Approach:

To begin, your arms from the shoulder to the elbow should be level to the ground. From the wrist to the elbow should be approximately at a 45-degree angle towards each other. Wrists are bent to allow for the cymbals to be parallel (see photo to the right). The cymbals should be 2-3 inches apart with the knots of the cymbals in line with your eyes. *See “visual applications” for more information. To prepare for the crash, open the cymbals up to an “A.” To do this, straighten the wrist to create a flat line from the tip of the fingers all the way to the elbow. Then, break the wrist back so the cymbals form a “V.” This is where the first crash or “grace note” happens at the bottom of the cymbals. The crash hits bottom then pushes through to the top and opens back up to the original “A” position. To finish, open back up to the “V” and snap back to set. (set, AV, ‘flam’, crash, AV, set = one crash) The snap to set should occur two counts after the crash (ex- crash on one, snap back on three).



This same “flam” technique should be applied to the orchestral position. In this instance, switch the “bottom to top” impacts to “heel of the palm to finger tips.” Otherwise, the AVAV visual technique is the same with the left arm using slightly less motion. For the orchestral, cymbals should be parallel to each other but at a 45 degree angle from the ground. The knots of the cymbal should line up with the center of your body both horizontally and vertically (your belly-button).

This information for crash technique is applied, with slight modification, to crash chokes. You will only use the first three positions – AVA. From the “A” position after the crash, bring the cymbals into your Latissimus dorsi (muscle that connects your shoulder and chest/underarm). Your cymbals should return from this dampened “A” position to the set position two counts after the crash (ex- choke on count one, out on count three). Experience with any other cymbal sounds is not necessary but strongly encouraged. These may include, but are not limited to: slide chokes, scrapes/zings, sizzles, taps, bell-taps, high-hats/hinge chokes, and cymbal rolls.

Visual Applications

The cymbal player is a big contributor to the overall visual program. Good posture is a necessity for playing and executing visuals well. When holding your cymbal at your sides in the “attention” position your shoulders should be relaxed and down. Keep your pelvis in line with your center (abs) and shoulders. Your arms should have a natural bend held firmly enough to control the cymbals. Your elbows should stay turned slightly outwards, not in towards your body. Keep the cymbals parallel to each other and approximately 2 inches from your sides. For cymbal players, the most basic visual element is the cymbal flip. To complete a “flip-up” you must start with your cymbals parallel to each other at your side. Keep your back straight, shoulders back and relaxed, and head up with your focus and weight slightly forward. A cymbal “flip” involves one simple rotation of the wrist: the thumb pushes back behind you and rotates the cymbal around to the front. Your arm should come forward and up simultaneously. Allow your arms to take a straight pathway up. To complete the flip you stop your cymbals parallel in front of your face, 2-3 inches apart, with the knots of the cymbals in line with your eyes. Be sure to account for “tunnel vision” when the cymbals are that close to your face. To force the cymbals to be parallel you must be able to see the inside far edge of the cymbal. A “flip down” is the exact reverse of the flip up. Pay careful attention to locking the cymbals in the attention position when flipping down. Practice these two elements slowly and work your way faster. An accurately done cymbal flip should happen instantaneously.

Physical Conditioning:

Playing cymbals is one of the most physically demanding assignments in the marching percussion ensemble. In order to perform comfortably it is important to develop strength and flexibility in those muscles that are most frequently used. Help prevent muscle cramps, wrist sprains, tendonitis and other injuries by stretching and applying strength training to your preparations for auditions. Remember, while push-ups are an excellent way to develop cymbal strength, no exercise compares to actually holding and playing the cymbals for extended periods of time. If you are not currently a part of a music program, see if your school or band director will allow you to borrow cymbals and practice on campus.

Technique for Auditions:

For auditions we will ask you to use whatever technique you are most comfortable with. Apply any new information from this hand out as necessary – ESPECIALLY the information on Sound Production. In addition, pay special attention to your posture. For the visual performer it is essential that you keep a straight back with relaxed shoulders. Timing and musicality will also play an important role in the audition process.



Tying Cymbal Straps:

Strap Size Adjustment

This simple weave is important for comfort in laying cymbals. It will keep the strap from bunching and it will allow it to lie comfortably across the web between your pointer finger and thumb.

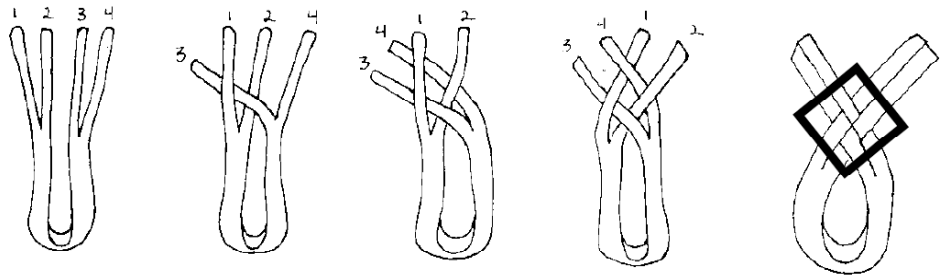

Cymbal Knot

It's very important your cymbal straps are tightly tied. Keeping the straps tight on your hands is the best way to maintain control of the cymbal. After tying, you should be able to hold the cymbal in a "ride" position and have the cymbal pads or bell firmly touching the palm of your hand.

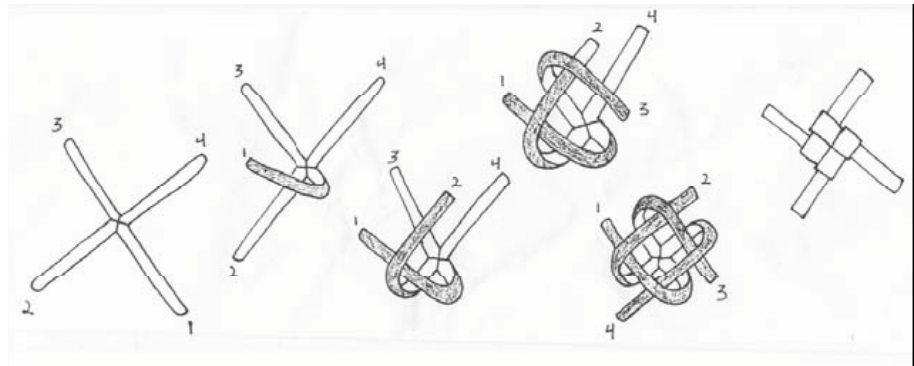

The Garfield Grip

1. Hold the cymbal in a vertical position and put your hand through the strap up to the wrist.
2. Turn the hand so the palm is facing away from the pad of the cymbal.
3. Rotate the entire hand downward and turn the palm toward the cymbal until it touches the pad. The strap should rest at the base of the thumb and forefinger.

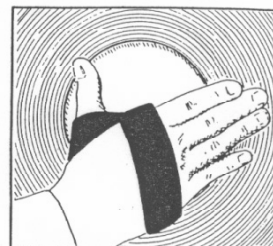
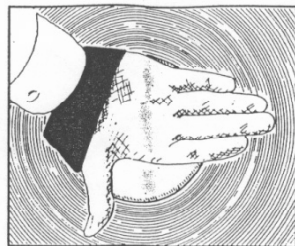
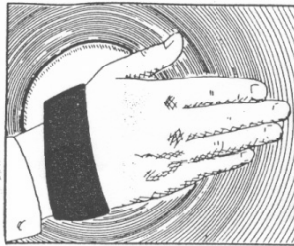

From
"Marching
Concepts"
by Thom
Hannum

Thanks for your interest in the Colts Cymbal Line. Please feel free to contact me with any questions you might have regarding auditions or the material in this packet.

Thien Quoc Pham-Tran

Cymbal Educator

thien.pham@cox.net

*NOTE: This packet was created and compiled by Lauren Sakowski. Lauren was the Colts Cymbal Tech from 2001-2007 and the current cymbal tech for the Gateway Percussion cymbal line. The information was adapted and modified by Thien Quoc Pham-Tran for the 2012 Colts Cymbal Line.